

SN54196, SN54197, SN54LS196, SN54LS197, SN54S196, SN54S197, SN74196, SN74197, SN74LS196, SN74LS197, SN74S196, SN74S197 50/30/100-MHz PRESETTABLE DECADE OR BINARY COUNTERS/LATCHES

OCTOBER 1976—REVISED MARCH 1988

- Performs BCD, Bi-Quinary, or Binary Counting
- Fully Programmable
- Fully Independent Clear Input
- Input Clamping Diodes Simplify System Design
- Output Q_A Maintains Full Fan-out Capability In Addition to Driving Clock-2 Input

SN54196, SN54LS196, SN54S196,
SN54197, SN54LS197, SN54S197 . . . J OR W PACKAGE
SN74196, SN74197 . . . N PACKAGE
SN74LS196, SN74S196,
SN74LS197, SN74S197 . . . D OR N PACKAGE

(TOP VIEW)

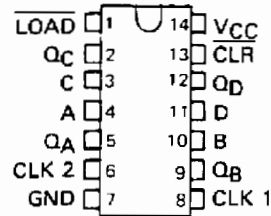

TYPES	GUARANTEED COUNT FREQUENCY		TYPICAL POWER DISSIPATION
	CLOCK 1	CLOCK 2	
'196, '197	0-50 MHz	0-25 MHz	240 mW
'LS196, 'LS197	0-30 MHz	0-15 MHz	80 mW
'S196, 'S197	0-100 MHz	0-50 MHz	375 mW

description

These high-speed monolithic counters consist of four d-c coupled, master-slave flip-flops, which are internally interconnected to provide either a divide-by-two and a divide-by-five counter ('196, 'LS196, 'S196) or a divide-by-two and a divide-by-eight counter ('197, 'LS197, 'S197). These four counters are fully programmable; that is, the outputs may be preset to any state by placing a low on the count/load input and entering the desired data at the data inputs. The outputs will change to agree with the data inputs independent of the state of the clocks.

During the count operation, transfer of information to the outputs occurs on the negative-going edge of the clock pulse. These counters feature a direct clear which when taken low sets all outputs low regardless of the states of the clocks.

These counters may also be used as 4-bit latches by using the count/load input as the strobe and entering data at the data inputs. The outputs will directly follow the data inputs when the count/load is low, but will remain unchanged when the count/load is high and the clock inputs are inactive.

All inputs are diode-clamped to minimize transmission-line effects and simplify system design. These circuits are compatible with most TTL logic families. Series 54, 54LS, and 54S circuits are characterized for operation over the full military temperature range of -55°C to 125°C; Series 74, 74LS, and 74S circuits are characterized for operation from 0°C to 70°C.

SN54LS196, SN54S196,
SN54LS197, SN54S197 . . . FK PACKAGE

(TOP VIEW)

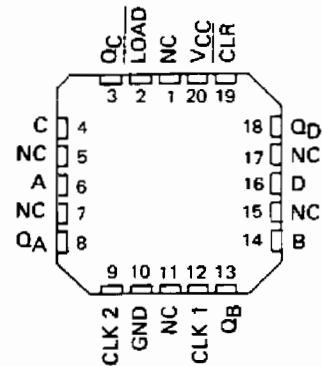

NC - No internal connection

logic symbols†

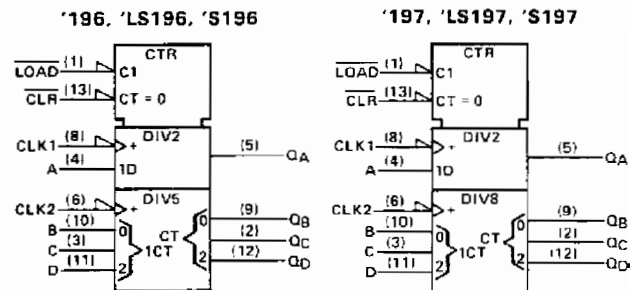

† These symbols are in accordance with ANSI/IEEE Std 91-1984 and IEC Publication 617-12. Pin numbers shown are for D, J, N, and W packages.

PRODUCTION DATA documents contain information current as of publication date. Products conform to specifications per the terms of Texas Instruments standard warranty. Production processing does not necessarily include testing of all parameters.



POST OFFICE BOX 655012 • DALLAS, TEXAS 75265

**SN54196, SN54197, SN54LS196, SN54LS197, SN54S196, SN54S197,
SN74196, SN74197, SN74LS196, SN74LS197, SN74S196, SN74S197
50/30/100-MHz PRESETTABLE DECADE OR BINARY COUNTERS/LATCHES**

typical count configurations

'196, 'LS196, and 'S196 typical count configurations and function tables are the same as those for '176.
'197, 'LS197, and 'S197 typical count configurations and function tables are the same as those for '177.

logic diagrams

'196, 'LS196, and 'S196 logic diagrams are the same as those for '176.
'197, 'LS197, and 'S197 logic diagrams are the same as those for '177.

schematics of inputs and outputs

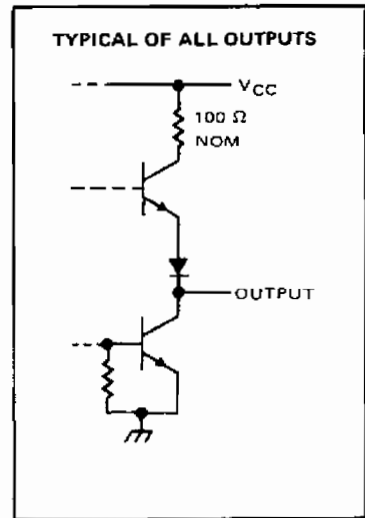
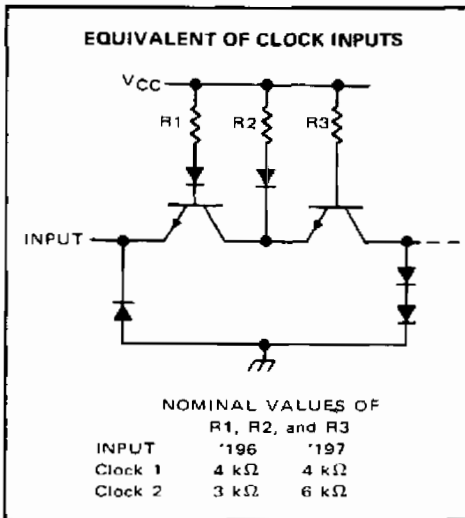
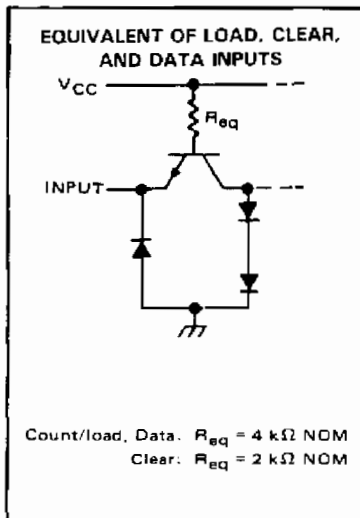

SN54196, SN54197, SN74196, SN74197 50-MHz PRESETTABLE DECADE OR BINARY COUNTERS/LATCHES

absolute maximum ratings over operating free-air temperature range (unless otherwise noted)

Supply voltage, V_{CC} (see Note 1)	7 V
Input voltage	5.5 V
Intermitter voltage (see Note 2)	5.5 V
Operating free-air temperature range: SN54196, SN54197 Circuits	-55°C to 125°C
SN74196, SN74197 Circuits	0°C to 70°C
Storage temperature range	-65°C to 150°C

- NOTES: 1. Voltage values are with respect to network ground terminal.
 2. This is the voltage between two emitters of a multiple-emitter transistor. For this circuit, this rating applies between the Clear and Load inputs.

recommended operating conditions

		SN54196, SN54197			SN74196, SN74197			UNIT
		MIN	NOM	MAX	MIN	NOM	MAX	
Supply voltage, V_{CC}		4.5	5	5.5	4.75	5	5.25	V
High-level output current, I_{OH}		-800			-800			μ A
Low-level output current, I_{OL}		16			16			mA
Count frequency	Clock-1 input	0	50		0	50		MHz
	Clock-2 input	0	25		0	25		
Pulse width, t_w	Clock-1 input	10			10			ns
	Clock-2 input	20			20			
	Clear	15			15			
	Load	20			20			
Input hold time, t_h (see Note 3)	High-level data	$t_w(\text{load})$			$t_w(\text{load})$			ns
	Low-level data	$t_w(\text{load})$			$t_w(\text{load})$			
Input setup time, t_{su} (see Note 3)	High-level data	10			10			ns
	Low-level data	15			15			
Count enable time, t_{en} (see Note 4)		20			20			ns
Operating free-air temperature, T_A		-55	125		0	70		°C

- NOTES: 3. Setup and hold times are with respect to the falling edge of the load input.
 4. Minimum count enable time is the interval immediately preceding the negative-going edge of the clock pulse during which interval the count/load and clear inputs must both be high to ensure counting.



SN54196, SN54197, SN74196, SN74197
50-MHz PRESETTABLE DECADE OR BINARY COUNTERS/LATCHES

electrical characteristics over recommended operating free-air temperature range (unless otherwise noted)

PARAMETER	TEST CONDITIONS†	SN54196, SN74196		SN54197, SN74197		UNIT
		MIN	TYP‡	MAX	MIN	
V _{IH} High-level input voltage		2			2	V
V _{IL} Low-level input voltage				0.8		0.8
V _{IK} Input clamp voltage	V _{CC} = MIN, I _I = -12 mA			-1.5		-1.5
V _{OH} High-level output voltage	V _{CC} = MIN, V _{IH} = 2 V, V _{IL} = 0.8 V, I _{OH} = -800 µA	2.4	3.4		2.4	3.4
V _{OL} Low-level output voltage	V _{CC} = MIN, V _{IH} = 2 V, V _{IL} = 0.8 V, I _{OL} = 16 mA¶		0.2	0.4		0.2
I _I Input current at maximum input voltage	V _{CC} = MAX, V _I = 5.5 V			1		1
I _{IH} High-level input current	Data, Load			40		40
	Clear, clock 1			80		80
	Clock 2			120		80
I _{IL} Low-level input current	Data, Load			-1.6		-1.6
	Clear			-3.2		-3.2
	Clock 1			-4.8		-4.8
	Clock 2			-6.4		-3.2
I _{OS} Short-circuit output current§	V _{CC} = MAX	SN54'		-20		-57
		SN74'		-18		-57
I _{CC} Supply current	V _{CC} = MAX, See Note 5		48	59		48

NOTE 5: I_{CC} is measured with all inputs grounded and all outputs open.

† For conditions shown as MIN or MAX, use the appropriate value specified under recommended operating conditions.

‡ All typical values are at V_{CC} = 5 V, T_A = 25°C.

§ Not more than one output should be shorted at a time.

¶ Q_A outputs are tested at I_{OL} = 16 mA plus the limit value of I_{IL} for the clock-2 input. This permits driving the clock-2 input while fanning out to 10 Series 54/74 loads.

switching characteristics, V_{CC} = 5 V, T_A = 25°C

PARAMETER #	FROM (INPUT)	TO (OUTPUT)	TEST CONDITIONS	SN54196		SN54197		UNIT	
				MIN	TYP	MAX	MIN		TYP
f _{max}	Clock 1	Q _A	C _L = 15 pF, R _L = 400 Ω. See Note 6	50	70		50	70	MHz
t _{PLH}	Clock 1	Q _A		7	12		7	12	ns
t _{PHL}				10	15		10	15	
t _{PLH}	Clock 2	Q _B		12	18		12	18	ns
t _{PHL}				14	21		14	21	
t _{PLH}	Clock 2	Q _C		24	36		24	36	ns
t _{PHL}				28	42		28	42	
t _{PLH}	Clock 2	Q _D		14	21		36	54	ns
t _{PHL}				12	18		42	63	
t _{PLH}	A, B, C, D	Q _A , Q _B , Q _C , Q _D		16	24		16	24	ns
t _{PHL}				25	38		25	38	
t _{PLH}	Load	Any		22	33		22	33	ns
t _{PHL}				24	36		24	36	
t _{PHL}	Clear	Any		25	37		25	37	ns

#f_{max} = maximum count frequency.

t_{PLH} = propagation delay time, low-to-high-level output.

t_{PHL} = propagation delay time, high-to-low-level output.

NOTE 6: Load circuit, input conditions, and voltage waveforms are the same as those shown for the '176, '177 except that testing f_{max}, V_{IL} = 0.3 V.



POST OFFICE BOX 655012 • DALLAS, TEXAS 75265

SN54LS196, SN54LS197, SN74LS196, SN74LS197 30-MHz PRESETTABLE DECADE OR BINARY COUNTERS/LATCHES

schematics of inputs and outputs

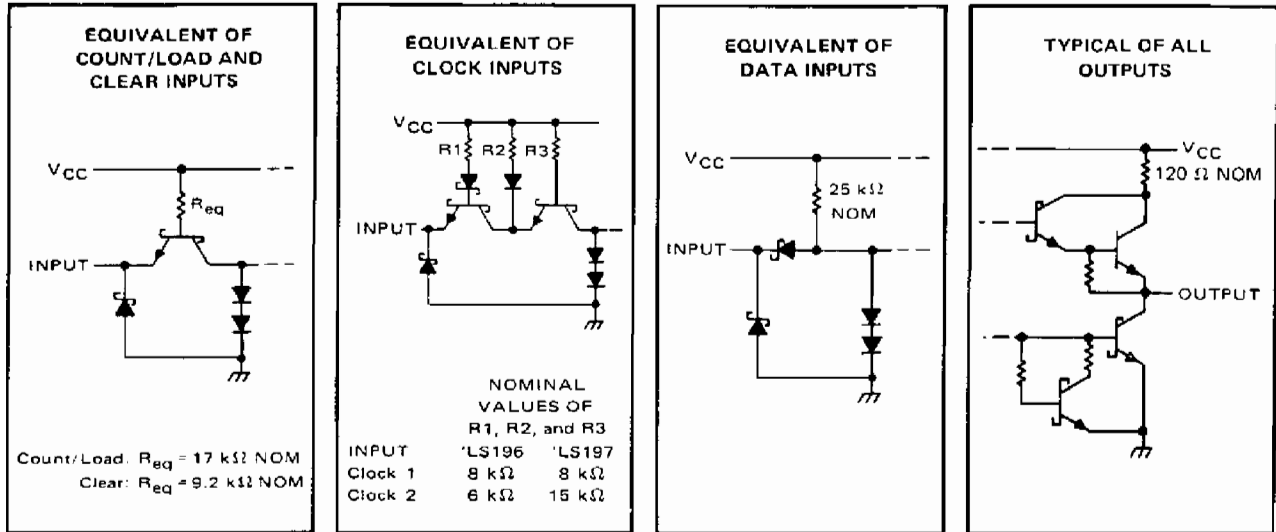

absolute maximum ratings over operating free-air temperature range (unless otherwise noted)

Supply voltage, V_{CC} (see Note 1)	7 V
Input voltage	5.5 V
Operating free-air temperature range: SN54LS196, SN54LS197 Circuits	-55°C to 125°C
SN74LS196, SN74LS197 Circuits	0°C to 70°C
Storage temperature range	-65°C to 150°C

NOTE 1: Voltage values are with respect to network ground terminal.

recommended operating conditions

		SN54LS196, SN54LS197			SN74LS196, SN74LS197			UNIT		
		MIN	NOM	MAX	MIN	NOM	MAX			
V_{CC}	Supply voltage	4.5	5	5.5	4.75	5	5.25	V		
I_{OH}	High-level output current				-400			μ A		
I_{OL}	Low-level output current				8			mA		
f_w	Pulse width	Count frequency						MHz		
		Clock-1 input	0	30	0	30				
		Clock-2 input	0	15	0	15				
		Load	20		20					
t_h	Input hold time, (see Note 3)	High-level data	$t_w(\text{load})$		$t_w(\text{load})$		ns			
		Low-level data	$t_w(\text{load})$		$t_w(\text{load})$					
t_{su}	Input setup time, (see Note 3)	High-level data	10		10		ns			
		Low-level data	15		15					
t_{enable}	Count enable time, (see Note 4)	Clock 1	30		30		ns			
		Clock 2	50		50					
T_A	Operating free-air temperature	-55			125			0	70	°C

NOTES: 3. Setup and hold times are with respect to the falling edge of the load input.

4. Minimum count enable time is the interval immediately preceding the negative-going edge of the clock pulse during which interval the count/load and clear inputs must both be high to ensure counting.



POST OFFICE BOX 655012 • DALLAS, TEXAS 75265

SN54LS196, SN54LS197, SN74LS196, SN74LS197

30-MHz PRESETTABLE DECADE OR BINARY COUNTERS/LATCHES

electrical characteristics over recommended operating free-air temperature range (unless otherwise noted)

PARAMETER		TEST CONDITIONS†	SN54LS196		SN74LS196		UNIT	
			SN54LS197	SN74LS197	MIN	TYP‡		MAX
V_{IH}	High-level input voltage		2		2		V	
V_{IL}	Low-level input voltage			0.7		0.8	V	
V_{IK}	Input clamp voltage	$V_{CC} = \text{MIN.}, I_I = -18 \text{ mA}$		-1.5		-1.5	V	
V_{OH}	High-level output voltage	$V_{CC} = \text{MIN.}, V_{IH} = 2 \text{ V}, V_{IL} = V_{IL \text{ max.}}, I_{OH} = -400 \mu\text{A}$	2.5	3.4	2.7	3.4	V	
V_{OL}	Low-level output voltage	$V_{CC} = \text{MIN.}, V_{IH} = 2 \text{ V}, V_{IL} = V_{IL \text{ max.}}$	$I_{OL} = 4 \text{ mA}^{\S}$		0.25	0.4	0.25	0.4
			$I_{OL} = 8 \text{ mA}^{\S}$				0.35	0.5
I_I	Input current at maximum input voltage	$V_{CC} = \text{MAX.}, V_I = 5.5 \text{ V}$	Data, Load		0.1		0.1	mA
			Clear, clock 1		0.2		0.2	
			Clock 2 of 'LS196		0.4		0.4	
			Clock 2 of 'LS197		0.2		0.2	
I_{IH}	High-level input current	$V_{CC} = \text{MAX.}, V_I = 2.7 \text{ V}$	Data, Load		20		20	μA
			Clear, clock 1		40		40	
			Clock 2 of 'LS196		80		80	
			Clock 2 of 'LS197		40		40	
I_{IL}	Low-level input current	$V_{CC} = \text{MAX.}, V_I = 0.4 \text{ V}$	Data, Load		-0.4		-0.4	mA
			Clear		-0.8		-0.8	
			Clock 1		-2.4		-2.4	
			Clock 2 of 'LS196		-2.8		-2.8	
			Clock 2 of 'LS197		-1.3		-1.3	
I_{OS}	Short-circuit output current \S	$V_{CC} = \text{MAX}$	-20	-100	-20	-100	mA	
I_{CC}	Supply current	$V_{CC} = \text{MAX.}$ See Note 5	16	27	16	27	mA	

† For conditions shown as MIN or MAX, use the appropriate value specified under recommended operating conditions.

‡ All typical values are at $V_{CC} = 5 \text{ V}, T_A = 25^\circ\text{C}$.

§ Not more than one output should be shorted at a time, and duration of the short-circuit should not exceed one second.

¶ Q_A outputs are tested at specified I_{OL} plus the limit value of I_{IL} for the clock-2 input. This permits driving the clock-2 input while maintaining full fan-out capability.

NOTE 5. I_{CC} is measured with all inputs grounded and all outputs open.

switching characteristics, $V_{CC} = 5 \text{ V}, T_A = 25^\circ\text{C}$

PARAMETER #	FROM (INPUT)	TO (OUTPUT)	TEST CONDITIONS	SN54LS196		SN54LS197		UNIT
				SN74LS196	SN74LS197	MIN	TYP	
f_{max}	Clock 1	Q_A	$C_L = 15 \text{ pF}, R_L = 2 \text{ k}\Omega, \text{ See Note 6}$	30	40	30	40	MHz
t_{PLH}	Clock 1	Q_A		8	15	8	15	ns
t_{PHL}				13	20	14	21	
t_{PLH}	Clock 2	Q_B		16	24	12	19	ns
t_{PHL}				22	33	23	35	
t_{PLH}	Clock 2	Q_C		38	57	34	51	ns
t_{PHL}				41	62	42	63	
t_{PLH}	Clock 2	Q_D		12	18	55	78	ns
t_{PHL}				30	45	63	95	
t_{PLH}	A, B, C, D	Q_A, Q_B, Q_C, Q_D		20	30	18	27	ns
t_{PHL}				29	44	29	44	
t_{PLH}	Load	Any		27	41	26	39	ns
t_{PHL}				30	45	30	45	
t_{PHL}	Clear	Any		34	51	34	51	ns

f_{max} = maximum count frequency.

t_{PLH} = propagation delay time, low-to-high-level output, t_{PHL} = propagation delay time, high-to-low-level output.

NOTE 6: Load circuit, input conditions, and voltage waveforms are the same as those shown for the '176, '177 except that $t_r \leq 15 \text{ ns}, t_f \leq 6 \text{ ns}, \text{ and } V_{\text{ref}} = 1.3 \text{ V}$ (as opposed to 1.5 V).

TEXAS
INSTRUMENTS

POST OFFICE BOX 655012 • DALLAS, TEXAS 75265

SN54S196, SN54S197, SN74S196, SN74S197 100-MHz PRESETTABLE DECADE OR BINARY COUNTERS/LATCHES

schematics of inputs and outputs

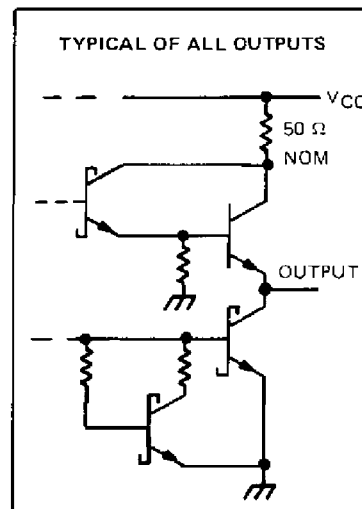
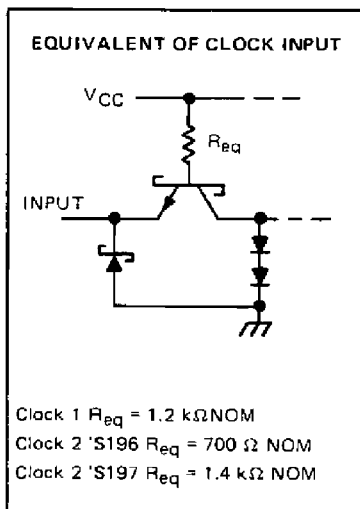
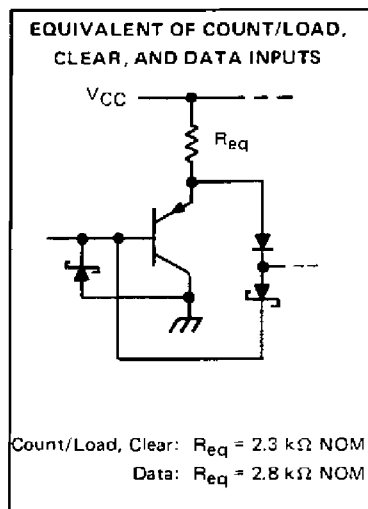

absolute maximum ratings over operating free-air temperature range (unless otherwise noted)

Supply voltage, V_{CC} (see Note 1)	7 V
Input voltage	5.5 V
Operating free-air temperature range: SN54S196, SN54S197 Circuits	-55°C to 125°C
SN74S196, SN74S197 Circuits	0°C to 70°C
Storage temperature range	-65°C to 150°C

NOTE 1: Voltage values are with respect to network ground terminal.

recommended operating conditions

		SN54S196, SN54S197			SN74S196, SN74S197			UNIT
		MIN	NOM	MAX	MIN	NOM	MAX	
Supply voltage, V_{CC}		4.5	5	5.5	4.75	5	5.25	V
High-level output current, I_{OH}		-1			-1			mA
Low-level output current, I_{OL}		20			20			mA
Clock frequency	Clock-1 input	0		100	0		100	MHz
	Clock-2 input	0		50	0		50	
Pulse width, t_w	Clock-1 input	5			5			ns
	Clock-2 input	10			10			
	Clear	30			30			
	Load	5			5			
Input hold time, t_H (see Note 3)	High-level data	31			31			ns
	Low-level data	31			31			
Input setup time, t_{SU} (see Note 3)	High-level data	61			61			ns
	Low-level data	61			61			
Count enable time, t_{EN} (see Note 4)		12			12			ns
Operating free-air temperature, T_A		-55		125	0		70	°C

NOTES: 3. Setup and hold times are with respect to the falling edge of the load input.

4. Minimum count enable time is the interval immediately preceding the negative-going edge of the clock pulse during which interval the count/load and clear inputs must both be high to ensure counting.



POST OFFICE BOX 655012 • DALLAS, TEXAS 75265

SN54S196, SN54S197, SN74S196, SN74S197

100-MHz PRESETTABLE DECADE OR BINARY COUNTERS/LATCHES

electrical characteristics over recommended operating free-air temperature range (unless otherwise noted)

PARAMETER	TEST CONDITIONS †	SN54S196, SN74S196		SN54S197, SN74S197		UNIT	
		MIN	TYP ‡	MAX	MIN		TYP ‡
V _{IH}		2		2		V	
V _{IL}		0.8		0.8		V	
V _{IK}	V _{CC} = MIN, I _I = -18 mA	-1.2		-1.2		V	
V _{OH}	V _{CC} = MIN, V _{IH} = 2 V, V _{IL} = 0.8 V, I _{OH} = -1 mA	54S	2.5	3.4	2.5	3.4	V
		74S	2.7	3.4	2.7	3.4	
V _{OL}	V _{CC} = MIN, V _{IH} = 2 V, V _{IL} = 0.8 V, I _{OL} = 20 mA ‡	0.5		0.5		V	
I _I	V _{CC} = MAX, V _I = 5.5 V	1		1		mA	
I _{IH}	Clock 1, clock 2	150		150		μA	
	All other inputs	50		50			
I _{IL}	Data, Load Clear	-0.75		-0.75		mA	
	Clock 1	-8		-8			
	Clock 2	-10		-6			
I _{OS} §	V _{CC} = MAX	-30	-110	-30	-110	mA	
I _{CC}	V _{CC} = MAX, See Note 5	54S	75	110	75	110	mA
		74S	75	120	75	120	

† For conditions shown as MIN or MAX, use the appropriate value specified under recommended operating conditions.

‡ All typical values are at V_{CC} = 5 V, T_A = 25°C.

§ Q_A outputs are tested at I_{OL} = 20 mA plus the limit value of I_{IL} for the clock-2 input. This permits driving the clock-2 input while fanning out to 10 Series 54S/74S loads.

§ Not more than one output should be shorted at a time, and duration of the short-circuit should not exceed one second.

NOTE 5: I_{CC} is measured with all input grounded and all outputs open.

switching characteristics, V_{CC} = 5 V, T_A = 25°C

PARAMETER #	(FROM (INPUT))	TO (OUTPUT)	TEST CONDITIONS	SN54S196, SN74S196		SN54S197, SN74S197		UNIT
				MIN	TYP	MAX	MIN	
f _{max}	Clock 1	Q _A	R _L = 280 Ω, C _L = 15 pF, See Note 7	100	140	100	140	MHz
t _{PLH}	Clock 1	Q _A		5	10	5	10	ns
t _{PHL}				6	10	6	10	
t _{PLH}	Clock 2	Q _B		5	10	5	10	ns
t _{PHL}				8	12	8	12	
t _{PLH}	Clock 2	Q _C		12	18	12	18	ns
t _{PHL}				16	24	15	22	
t _{PLH}	Clock 2	Q _D		5	10	18	27	ns
t _{PHL}				8	12	22	33	
t _{PLH}	A,B,C,D	Q _A ,Q _B ,Q _C ,Q _D		7	12	7	12	ns
t _{PHL}				12	18	12	18	
t _{PLH}	Load	Any		10	18	10	18	ns
t _{PHL}				12	18	12	18	
t _{PHL}	Clear	Any		26	37	26	37	ns

#f_{max} = maximum count frequency.

t_{PLH} = propagation delay time, low-to-high-level output.

t_{PHL} = propagation delay time, high-to-low-level output.

NOTE 7: Load circuit, input conditions, and voltage waveforms are the same as those shown in Section 1.

TEXAS
INSTRUMENTS

POST OFFICE BOX 655012 • DALLAS, TEXAS 75265

IMPORTANT NOTICE

Texas Instruments (TI) reserves the right to make changes to its products or to discontinue any semiconductor product or service without notice, and advises its customers to obtain the latest version of relevant information to verify, before placing orders, that the information being relied on is current.

TI warrants performance of its semiconductor products and related software to the specifications applicable at the time of sale in accordance with TI's standard warranty. Testing and other quality control techniques are utilized to the extent TI deems necessary to support this warranty. Specific testing of all parameters of each device is not necessarily performed, except those mandated by government requirements.

Certain applications using semiconductor products may involve potential risks of death, personal injury, or severe property or environmental damage ("Critical Applications").

TI SEMICONDUCTOR PRODUCTS ARE NOT DESIGNED, INTENDED, AUTHORIZED, OR WARRANTED TO BE SUITABLE FOR USE IN LIFE-SUPPORT APPLICATIONS, DEVICES OR SYSTEMS OR OTHER CRITICAL APPLICATIONS.

Inclusion of TI products in such applications is understood to be fully at the risk of the customer. Use of TI products in such applications requires the written approval of an appropriate TI officer. Questions concerning potential risk applications should be directed to TI through a local SC sales office.

In order to minimize risks associated with the customer's applications, adequate design and operating safeguards should be provided by the customer to minimize inherent or procedural hazards.

TI assumes no liability for applications assistance, customer product design, software performance, or infringement of patents or services described herein. Nor does TI warrant or represent that any license, either express or implied, is granted under any patent right, copyright, mask work right, or other intellectual property right of TI covering or relating to any combination, machine, or process in which such semiconductor products or services might be or are used.